

DESULFATER.COM

Electronic Battery Desulfater, Conditioner and Reactivator

KEEP THE LIFE INSIDE YOUR BATTERY!

INSTALLATION AND USER MANUAL

FOR MODELS 12V1000 SERIES

ELECTRONIC BATTERY DESULFATER



Thank you for purchasing the finest Electronic Battery Desulfater available on the market. Please make sure to read this whole manual to correctly install it, and get the most benefit and best return on your investment. This manual also includes a section that explains how the desulfater works, and expected results.

PREPARING FOR THE INSTALLATION

Please always make sure to adequately ventilate the area of the batteries before starting the installation, as there is always a possibility of an accumulation of hydrogen gas that might occur during the normal charging cycle. Hydrogen gas in high enough concentration can ignite when exposed to sparks or open flames, and become highly explosive, and even rupture a battery. Also carefully inspect all the battery terminals to insure they are clean and free of any corrosion signs. If required, clean thoroughly and use a soft metal brush to gently expose bare (shiny) lead on the battery posts at the electrical contact area. Club Soda can be used to neutralize any acid residue on top of the battery or terminals to inhibit further corrosion. Most marine and solar/wind system batteries are also equipped with threaded connection studs besides the regular post. If these studs are available, it is always recommended to use them as they provide a more secure attachment point. Otherwise use the tightening screw of the battery post clamp, or get specially designed clamps that will provide a threaded stud connection. Again, make sure these clamps are secure, clean, and absolutely free of corrosion. Loose or corroded battery post clamps, or defective cable crimping will cause losses, overheating of the connection under high current demand, and/or intermittent connections that will prevent the battery from being fully charged, and/or cause voltage transients that could damage sensitive electronic equipment connected to the battery. Always check battery connecting cables and jumpers by carefully tugging at them with some force to test that all connections are tight and secure. Any loose or defective connections should be immediately replaced or repaired by a qualified technician. This is VERY important for the operating safety and reliability of any battery system. Also, your electronic desulfater will not be able to operate efficiently if installed on defective battery connections.

INSTALLATION STEPS (1-2-3)

STEP 1. Connect the BLACK cable to the minus/negative (-) side of the battery, and tighten down well.

STEP 2. Connect the RED cable to the plus/positive (+) side of the battery, and also tighten down well.

Note: it is normal to see faint sparks on the terminals when initially hooking up the desulfater. The sparking is caused by the high frequency nature of the desulfating pulses, even though the actual consumption of the desulfater is very low, on average no more than (0.065A / 65 milli-Amps).

At this point your electronic battery desulfater should be operating. The red LED light should be illuminated, and a faint high-pitched buzz should be heard coming from the box. If this is not the case, check the voltage of the battery. If the voltage is lower than 12.4~12.5V the 12V1000-AT desulfater will not power up to protect the battery from further discharging, and in that case you will need to first recharge the battery for it to start operating. You can leave the desulfater connected to the battery, and it will automatically power up when a minimum voltage of 12.5V has been reached. For unattended batteries, the model 12V1000-AT desulfater will also automatically shut down if for any reason the battery voltage gets to 12.1V or lower, to prevent it from damaging the battery by causing a deep discharge, and will not repower up until 12.5V is reached. The more economical model 12V1000-M will run continuously as it does not have the voltage sense function, so it is only recommended to be used in cases where the battery will always be closely monitored, so the risk of a deep discharge is comparably very low.

STEP 3. Secure the electronic box by way of two screws with the mounting ears, or with the included Velcro tape. **Warning:** do not mount the electronic box of your desulfater near a source of heat, or on surfaces that will get hot. If possible, try to keep the box away from any battery vents or caps, to minimize exposure to acid.

A NOTE ABOUT OTHER BATTERY BANK CONFIGURATIONS (6V batteries wired for 12V, or 12V batteries wired for 24V). If your system uses 6 Volt batteries connected in SERIES, so its voltage will add up to 12V, or it uses 12V batteries also wired in series to provide 24V, please read on the following explanation and take a look at the diagrams below to understand how to connect your desulfater in these cases.

Case study 1: System voltage is 12V, but battery bank uses 6V batteries wired in SERIES to add up the voltage to 12V. **Solution:** hook up your 12V electronic battery desulfater so it is connected across two 6V batteries. This way it will operate on 12V as the voltage of the two batteries is summed. Note: there might also be additional batteries wired in parallel, but that will not have effect on the voltage, and is done only to increase current capacity of the system. Please refer to the picture bellow left as a guide to connect your 12V desulfater so it will operate on the correct voltage range, and can be effective in preventing battery sulfate buildup for this configuration, for up to 1000Ah of total bank capacity.

Case study 2: System voltage is 24V, but battery bank uses 12V batteries wired in SERIES to add up the voltage to 24V. **Solution:** hook up one 12V electronic battery desulfater so it is connected across each 12V battery. This way it will only see a single 12V battery. Note: there might also be additional batteries wired in parallel, but that will not have effect on the voltage, and is done only to increase current capacity of the system. Please refer to the picture bellow right as a guide to connect your 12V desulfater so it will operate on the correct voltage range, and can be effective in preventing battery sulfate buildup for this configuration, for up to 2000Ah of total bank capacity.

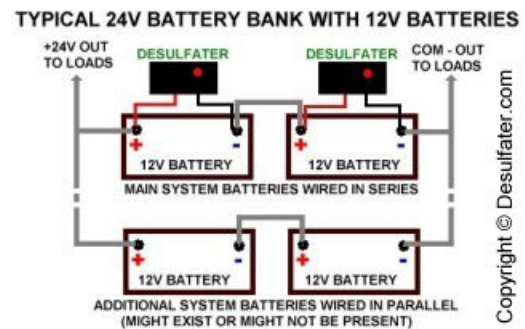
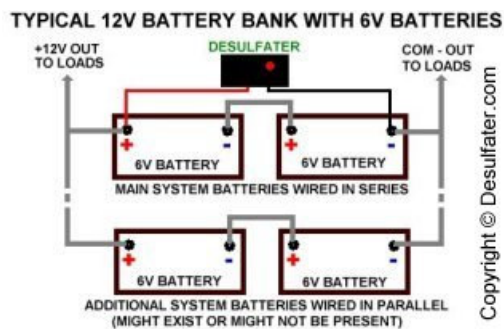

INSTALLATION NOTES AND OTHER VERY IMPORTANT CONSIDERATIONS

Make *absolutely sure* you have determined the correct polarity orientation at the battery before attempting to connect the electronic battery desulfater. If you reverse the polarity of the connection, even for a second, the internal protection fuse will blow. But in some cases, due to the high current of the battery, there is still a chance that the internal electronics of your desulfater will also be damaged. Fuses are unfortunately not always foolproof, and they are mainly there to prevent any fire hazard due to a short circuit.

If at any point you feel that this installation procedure is more than you are willing to do, or able to safely handle, please consult a qualified specialist to complete the installation for you. In certain cases where applicable, we do offer a free desulfater installation along with a baseline battery checkup of its critical parameters (voltage, CCA capacity, and internal resistance) to determine its current condition. Please contact us for more information.

Your electronic battery desulfater comes with 30cm (1ft) of cable. Shorter cables are always best for the efficiency of the desulfating process, as it relies on high frequency pulses. If desired you may cut any excess cable length, but always attach new ring terminals at the cable ends before making the connection to the battery. Also, if required, and at no additional cost, we can supply the 12V1000 electronic desulfater with 60cm (2ft) extended cables if your installation requires additional connection length. If you find yourself in need to splice the connecting cable in order to extend its reach, always use heavy gauge wire, at least #12. It is not recommended to have wires longer than 60cm/2ft. Never use any smaller size wire, as the high frequency pulses of the desulfater will be greatly attenuated, or blocked from fully reaching the battery, so the desulfating process will be less efficient, and take longer.

Due to the high-frequency nature of the desulfating pulses, they will only be present at the battery, and will not be able to travel over any longer electrical wiring as it will present a path of very high resistance to the pulses. Due to this, no sensitive electronic equipment connected to your battery (or bank) will be affected by the pulses.

THE DESULFATING PROCESS

Our electronic battery desulfater actively dislodges and removes the lead sulfate that builds up on the battery plates due to age and/or improper maintenance. It does so by continuously injecting high frequency electronic pulses into the battery plates. This will cause the sulfate to resonate (vibrate) ever so slightly, but the continuous process will ultimately break it up, cleaning the contact area of the plate with the battery acid (electrolyte) and restoring battery capacity. The dislodged sulfate will be safely reabsorbed and made once again available for the internal chemical reaction. These pulses will not harm the battery in any way, only the sulfate on the plates will be affected. On a moderately sulfated battery the process will usually take 4-6 weeks before improvements can be noticed. On a new "fresh" off the shelf battery it will prevent the buildup of sulfate in the first place, even during conditions that would normally promote it. The main effect in both cases is a prolonged battery service life and improved overall current capacity. But not all batteries are candidates for desulfation. A battery will be unrecoverable if the active material has been lost from the plates, has internal shorted cell plates, or if the plates are bent or deformed due to over temperature or over charging. On the other hand, a battery that has been left uncharged for a long time, but is otherwise undamaged, is most of the time a good restoration candidate, as it will only be suffering of sulfate buildup. In cases where its voltage cannot be maintained at 12V, a trickle charger might need to be left connected to the battery for the desulfater to be able to operate.

Pulsed conditioners like our electronic battery desulfater have a long history in the maintenance of batteries, but its contributions have only been recently studied and understood in more detail. The main benefit comes from the mechanical resonant energy that each pulse gives the plate. The pulses slowly but surely manage to weaken and loosen most of the sulfate buildup, and by doing so, slowly restore the working surface of the plate. This increase of "clean" surface area allows in term that the battery to increase its capacity, and makes it easier for it to accept a charge, by way of lowering its internal resistance.

But keep in mind that even with all the advantages of electronic desulfating, in certain cases there are batteries that will present an advanced state of failure that is beyond restoration and even by connecting our desulfater for extended periods will only yield marginal results, or none at all. In our own experience the opportunities to restore the capacity of a given battery are maximized if the desulfating treatment is started as soon as the first symptoms of diminished capacity appear, for example when a starter begins to have trouble turning over the engine. The chances of saving a battery are very limited if the battery gets to a point where it is barely able to engage the starter.

WARRANTY STATEMENT: Our Electronic Battery Desulfater is warranted for 12 months past the date of purchase against any manufacturing defects. This warranty does not cover damages by improper use or installation, corrosion, water damage, or reversed polarity connection. We will repair or replace any defective unit at our own criteria that would best suit the customers interest.

For service, technical support, or comments and/or suggestions, please contact us at:

DESULFATER.COM (www.desulfater.com)

Telephone (M-F 9-5)

- US/Caribbean: +1.721.559.5077
- European Union: +590.690.87.28.87
- Fax/Voicemail: +1.413.771.0372

Email

- info@desulfater.com
- support@desulfater.com
- tech@desulfater.com



End of this document.